

GEOMETRIE / VELIKOST

LEE COUGAN CROSSFIRE 428

	S	M	L
SEAT TUBE (ST)	420 mm	460 mm	495 mm
TOP TUBE (TT)	585 mm	605 mm	625 mm
HEAD TUBE (HT)	95 mm	105 mm	115 mm
CHAIN STAY (CS)	128	128	128
HEAD TUBE ANGLE (HA)	68.5°	68.5°	68.5°
SEAT TUBE ANGLE (SA)	74°	74°	74°
WHEEL BASE (WB)	1105 mm	1126 mm	1147 mm
REACH (R)	417 mm	434 mm	451 mm
STACK (S)	588 mm	597 mm	606 mm
BB HEIGHT (BH)	330 mm	330 mm	330 mm
STEM	80 mm	90 mm	100 mm

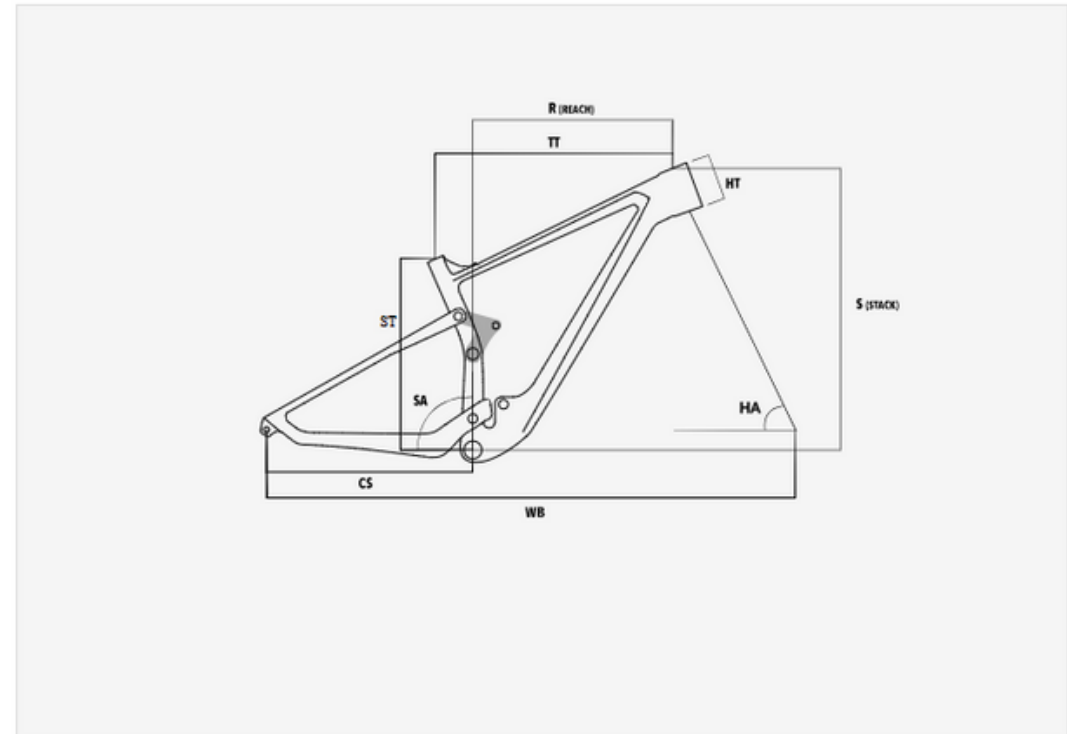

GEOMETRIE / VELIKOST

LEE COUGAN RAMPAGE INNOVA

	S	M	L
SEAT TUBE (ST)	420 mm	475 mm	515 mm
TOP TUBE (TT)	590 mm	615 mm	625 mm
HEAD TUBE (HT)	100 mm	105 mm	115 mm
CHAIN STAY (CS)	428 mm	428 mm	428 mm
HEAD TUBE ANGLE (HA)	69°	69°	69°
SEAT TUBE ANGLE (STA)	73°	73°	73°
WHEEL BASE (WB)	1107.6 mm	1133 mm	1143.7 mm
REACH (R)	428.5 mm	452 mm	459.2 mm
STACK (S)	616.1 mm	621.1 mm	630.5 mm
BB HEIGHT (BH)	310 mm	310 mm	310 mm
STEM	80 mm	90 mm	100 mm

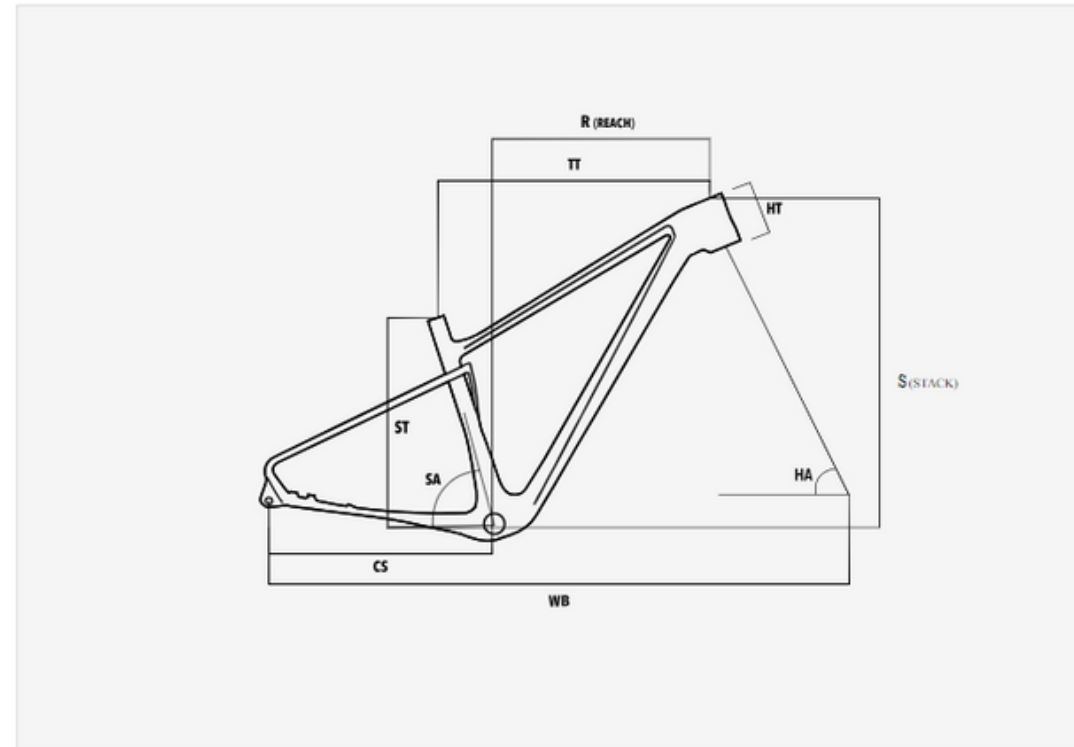

GEOMETRIE / VELIKOST

LEE COUGAN RAMPAGE 428

	XS	S	M	L
SEAT TUBE (ST)	400 mm	420 mm	470 mm	510 mm
TOP TUBE (TT)	570 mm	590 mm	615 mm	625 mm
HEAD TUBE (HT)	100 mm	100 mm	100 mm	100 mm
CHAIN STAY (CS)	428 mm	429 mm	430 mm	431 mm
HEAD TUBE ANGLE (HA)	70°	70°	70°	70°
SEAT TUBE ANGLE (SA)	73°	73°	73°	73°
WHEEL BASE (WB)	1076 mm	1096 mm	1109 mm	1132 mm
REACH (R)	408 mm	428 mm	451 mm	459 mm
STACK (S)	619 mm	619 mm	623 mm	623 mm
BB HEIGHT (BH)	310 mm	310 mm	310 mm	310 mm
STEM LENGHT	80 mm	90 mm	100 mm	110 mm

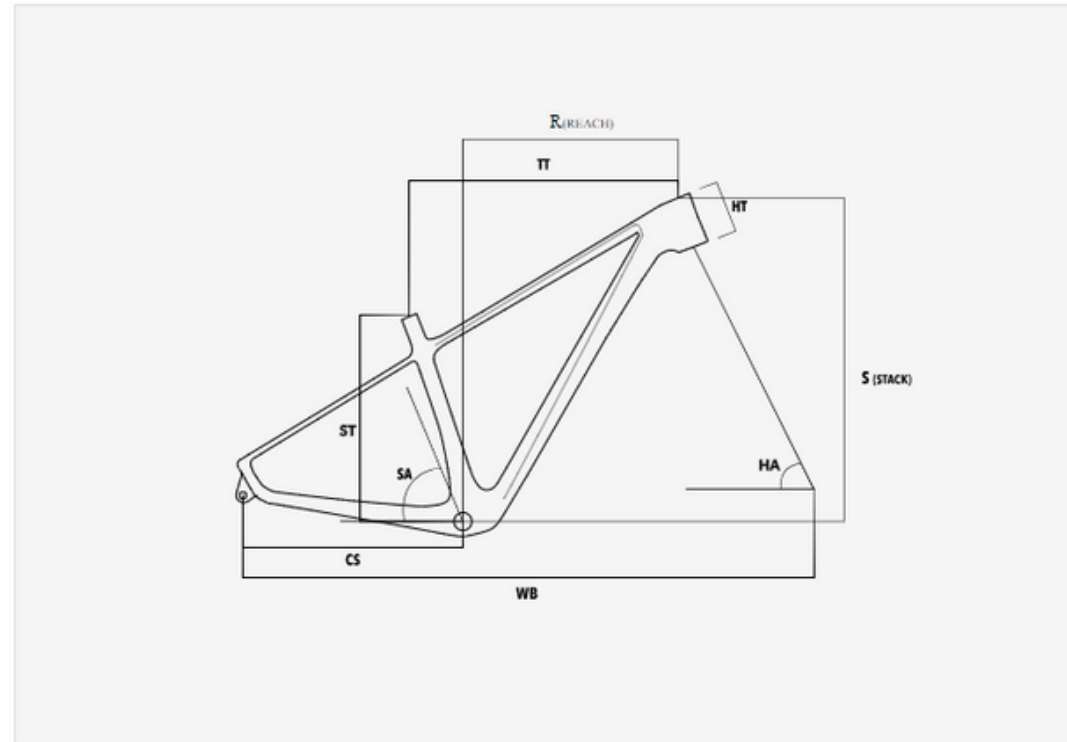

GEOMETRIE / VELIKOST

LEE COUGAN REVENGE

	X S	S	M	L
SEAT TUBE (ST)	390 mm	430 mm	470 mm	500 mm
TOP TUBE (TT)	565 mm	595 mm	615 mm	630 mm
HEAD TUBE (HT)	107 mm	107 mm	107 mm	107 mm
CHAIN STAY (CS)	440 mm	440 mm	440 mm	440 mm
HEAD TUBE ANGLE (HA)	70°	70°	70°	70°
SEAT TUBE ANGLE (SA)	72.7°	72.7°	72.7°	72.7°
FRONT CENTER (FC)	633 mm	663 mm	683 mm	698 mm

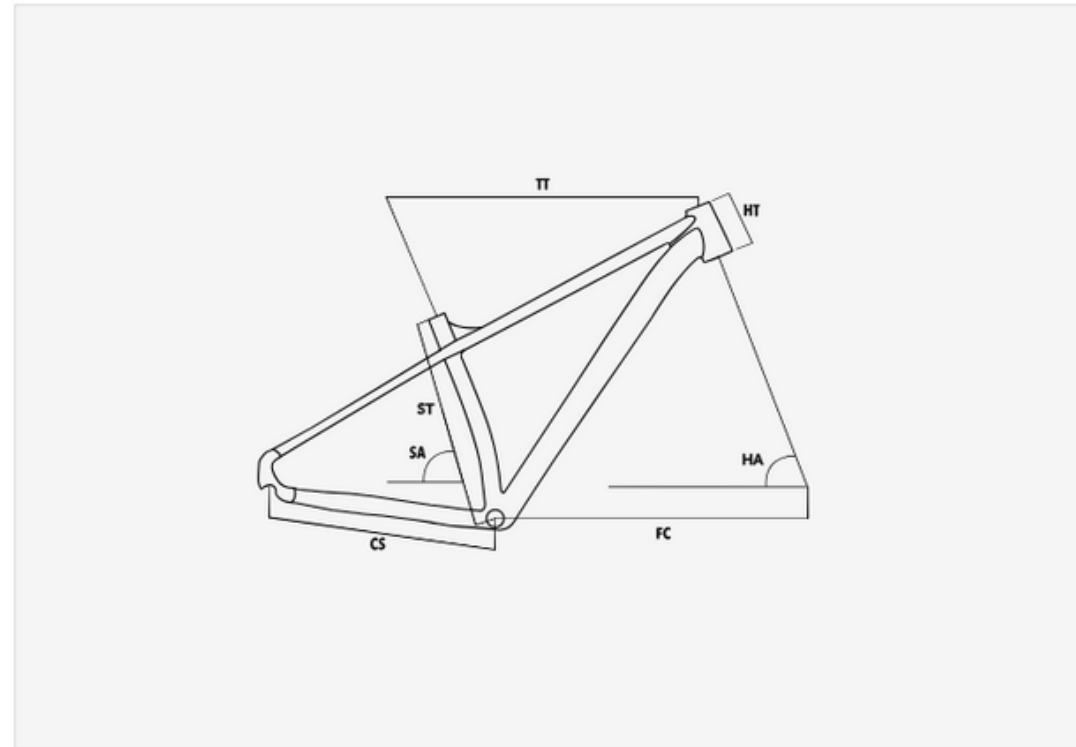

GEOMETRIE / VELIKOST

LEE COUGAN DROID

	XS	S	M	L
SEAT TUBE (ST)	390 mm	430 mm	470 mm	500 mm
TOP TUBE (TT)	565 mm	595 mm	615 mm	630 mm
HEAD TUBE (HT)	107 mm	107 mm	107 mm	107 mm
CHAIN STAY (CS)	440 mm	440 mm	440 mm	440 mm
HEAD TUBE ANGLE (HA)	70°	70°	70°	70°
SEAT TUBE ANGLE (SA)	72.7°	72.7°	72.7°	72.7°
FRONT CENTER (FC)	633 mm	663 mm	683 mm	698 mm

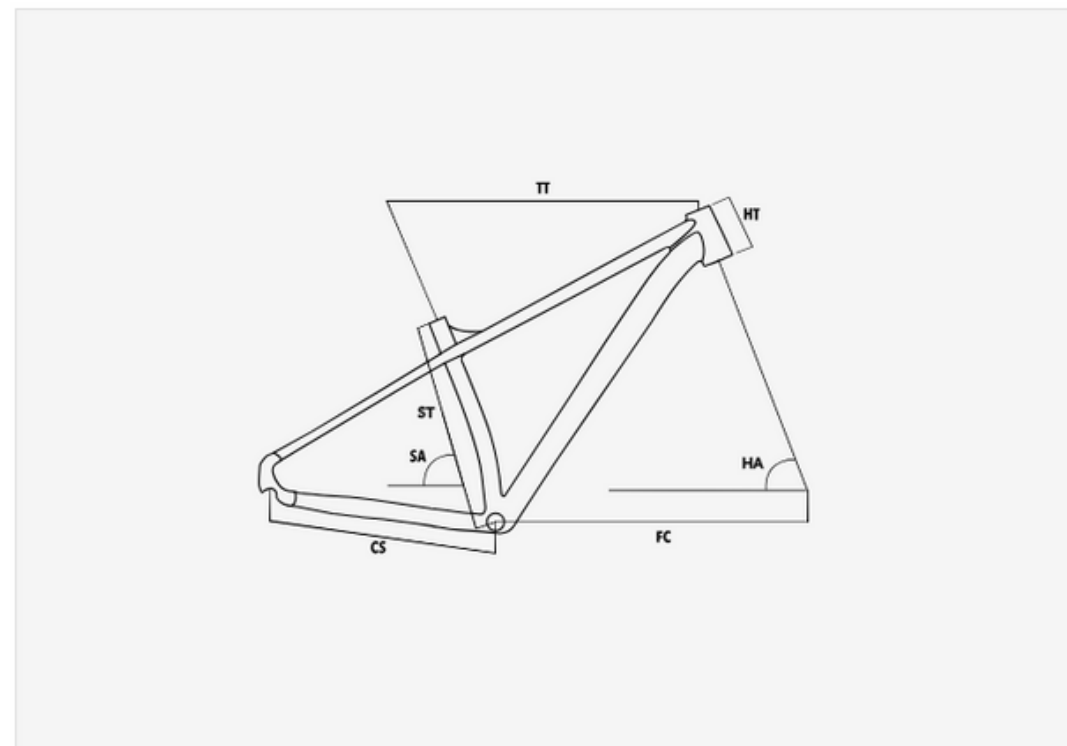

GEOMETRIE / VELIKOST

LEE COUGAN NITRO

	XS	S	M	L
SEAT TUBE (ST)	390 mm	430 mm	480 mm	510 mm
TOP TUBE (TT)	572 mm	592 mm	615 mm	630 mm
HEAD TUBE (HT)	100 mm	100 mm	100 mm	100 mm
CHAIN STAY (CS)	445 mm	445 mm	445 mm	445 mm
HEAD TUBE ANGLE (HA)	71°	71°	71°	71°
SEAT TUBE ANGLE (SA)	73°	73°	73°	73°
FRONT CENTER (FC)	625 mm	644 mm	667 mm	682 mm

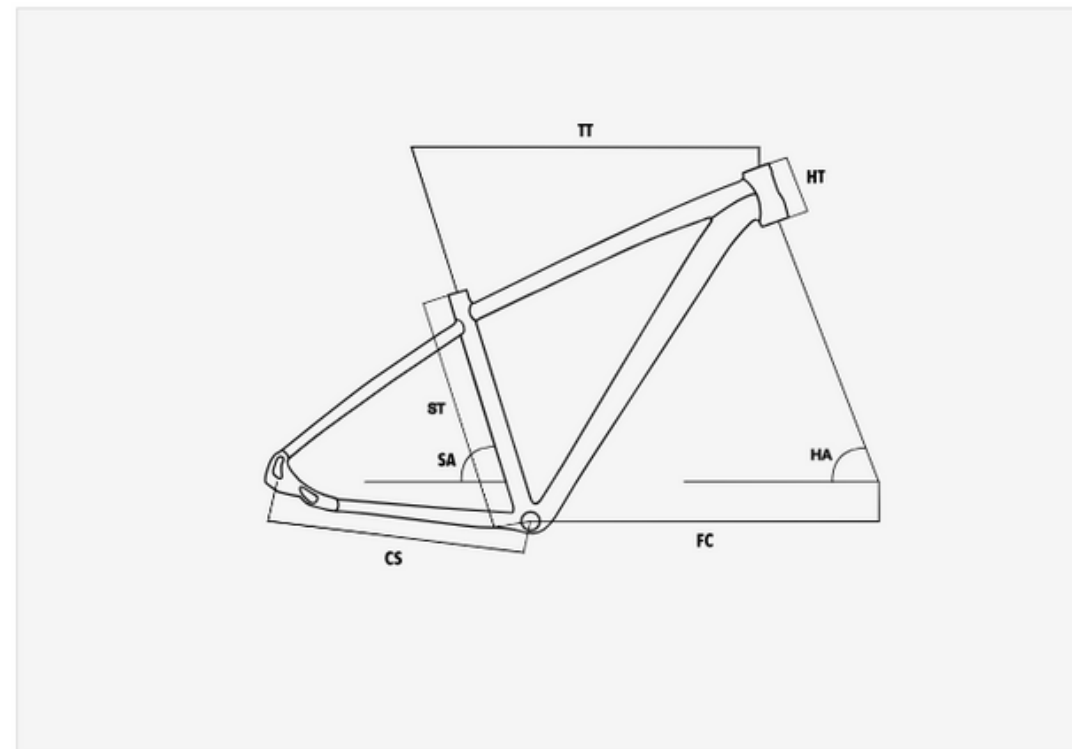

GEOMETRIE / VELIKOST

LEE COUGAN REBEL

	XS	S	M	L
SEAT TUBE (ST)	390 mm	430 mm	480 mm	510 mm
TOP TUBE (TT)	572 mm	592 mm	615 mm	630 mm
HEAD TUBE (HT)	100 mm	100 mm	100 mm	100 mm
CHAIN STAY (CS)	445 mm	445 mm	445 mm	445 mm
HEAD TUBE ANGLE (HA)	71°	71°	71°	71°
SEAT TUBE ANGLE (SA)	73°	73°	73°	73°
FRONT CENTER (FC)	625 mm	644 mm	667 mm	682 mm

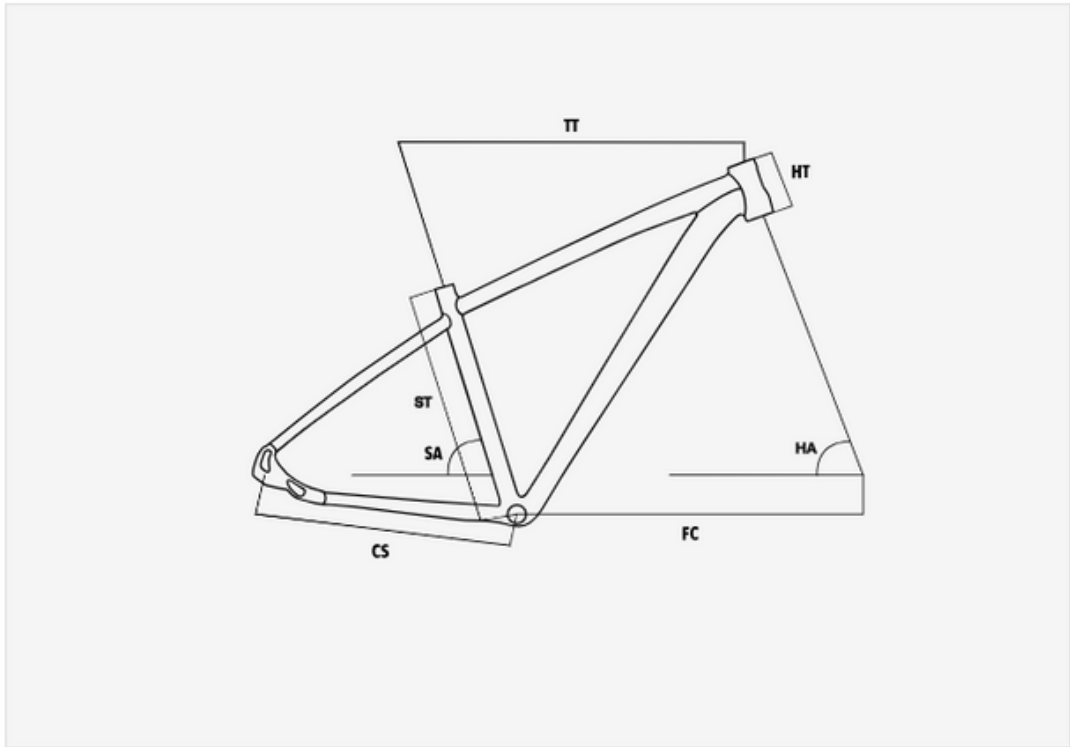

GEOMETRIE / VELIKOST LEE COUGAN QUEST

	S	M	L
SEAT TUBE (ST)	405 mm	445 mm	490 mm
TOP TUBE (TT)	405 mm	610 mm	625 mm
HEAD TUBE (HT)	105 mm	110 mm	110 mm
CHAIN STAY (CS)	455 mm	455 mm	455 mm
HEAD TUBE ANGLE (HA)	65.5°	65.5°	65.5°
SEAT TUBE ANGLE (SA)	75.4°	75.4°	75.4°
FRONT CENTER (FC)	717.5 mm	759.2 mm	774.2 mm

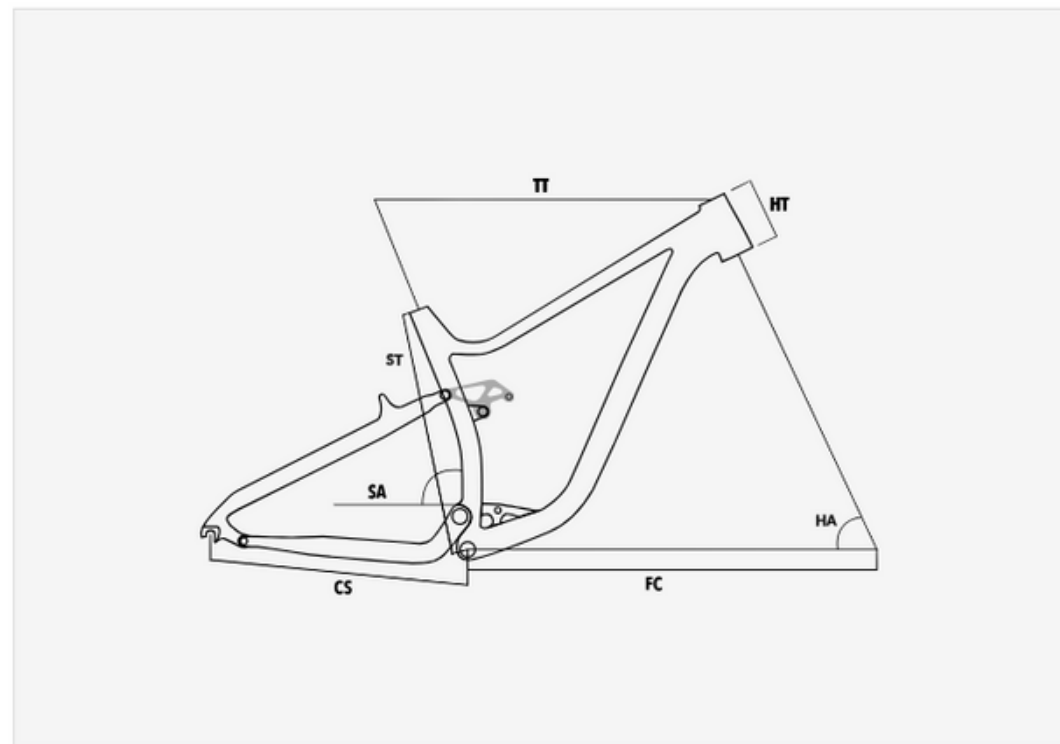

GEOMETRIE / VELIKOST LEE COUGAN E-QUEST

	S	M	L
SEAT TUBE (ST)	420 mm	450 mm	480 mm
TOP TUBE (TT)	608 mm	628 mm	651 mm
HEAD TUBE (HT)	115 mm	115 mm	125 mm
CHAIN STAY (CS)	460 mm	460 mm	460 mm
HEAD TUBE ANGLE (HA)	66.5°	66.5°	66.5°
SEAT TUBE ANGLE (SA)	73.5°	73.5°	73.5°
WHEEL BASE (WB)	1202 mm	1222 mm	1232 mm
STACK (S)	616 mm	620 mm	628 mm
REACH (R)	425 mm	445 mm	465 mm

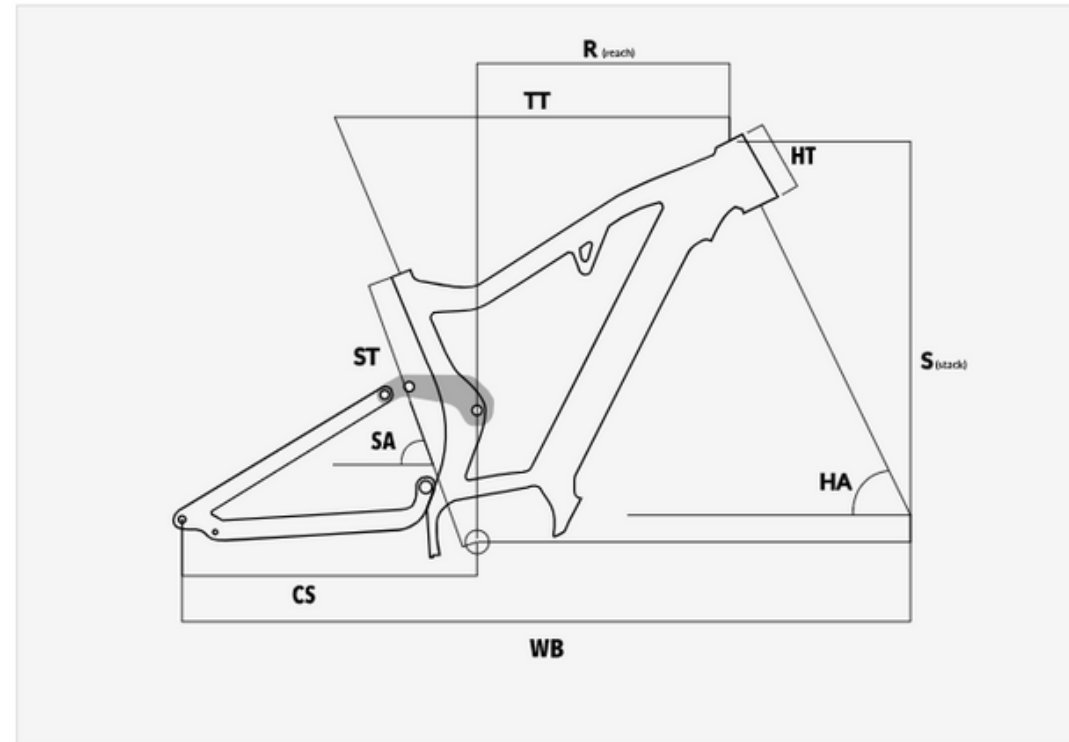

GEOMETRIE / VELIKOST LEE COUGAN MOVEDA

	S	M	L
SEAT TUBE (ST)	400 mm	450 mm	490 mm
TOP TUBE (TT)	580 mm	610 mm	620 mm
HEAD TUBE (HT)	140 mm	140 mm	140 mm
CHAIN STAY (CS)	470 mm	470 mm	470 mm
HEAD TUBE ANGLE (HA)	69°	69°	69°
SEAT TUBE ANGLE (SA)	73°	73°	73°
WHEEL BASE (WB)	1158 mm	1168 mm	1178 mm
STEM	80 mm	90 mm	100 mm

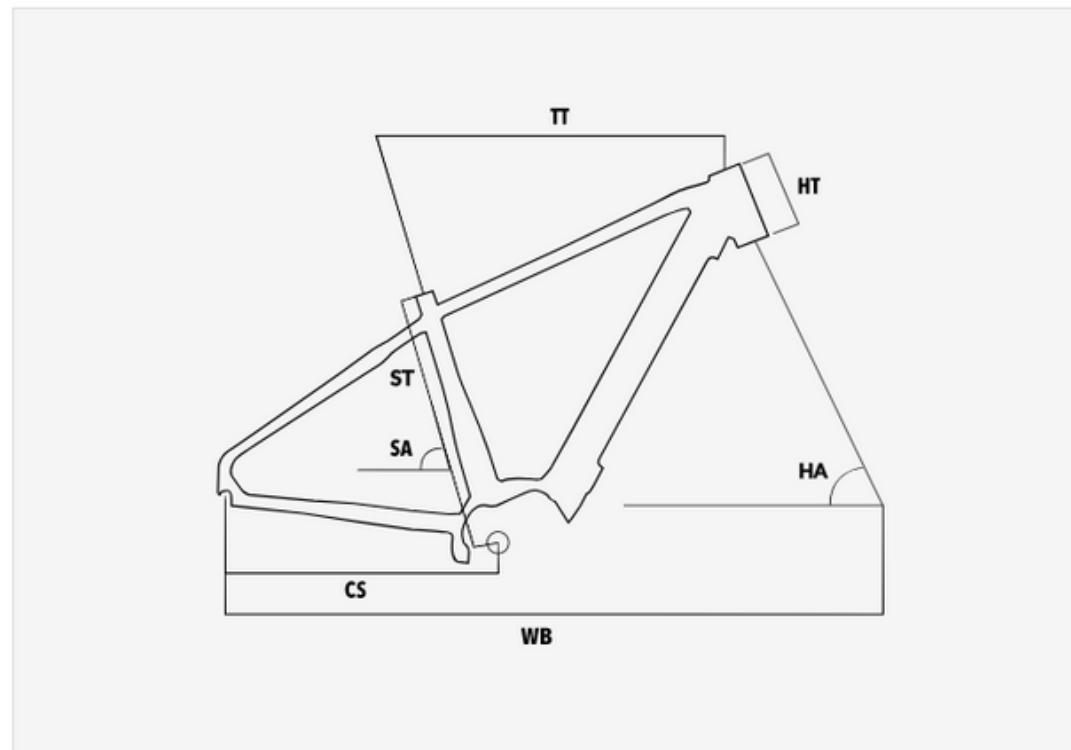

GEOMETRIE / VELIKOST LEE COUGAN DENAMO

	S	M
SEAT TUBE (ST)	420 mm	470 mm
TOP TUBE (TT)	560 mm	590 mm
HEAD TUBE (HT)	130 mm	130 mm
CHAIN STAY (CS)	460 mm	460 mm
HEAD TUBE ANGLE (HA)	69°	69°
SEAT TUBE ANGLE (SA)	73°	73°
WHEEL BASE (WB)	1106 mm	1136 mm

